

THIS DRAWING IS UNPUBLISHED. RELEASED FOR PUBLICATION
 © COPYRIGHT - By - ALL RIGHTS RESERVED.

LOC	DIST	REVISIONS			
P	LTR	DESCRIPTION	DATE	DWN	APVD
G	86				
	H5	REVISED PER ECO-15-011448	13OCT2015	NK	MM

- 1 STAMP " AMP 18-16"
- 2 FOR 1.40 TO 3.43 [.055 TO .135] WIRE INSULATION DIA.
- 3 TONGUE MATERIAL THK: 0.79±0.05 [.031±.002]
- 4 BODY: MATERIAL: COPPER ASTM B152
FINISH: GOLD PL. PER ASTM B488, TYPE 2 GRADE C, 0.00254 [.000100] MIN EXT THK OVER NICKEL PER (QQ-N-290) 0.00076 [.000030] EXT. THK.
- 5 SLEEVE: MATERIAL: COPPER ASTM B152
FINISH: NICKEL PL. (QQ-N-290) 0.00076 [.000030] AVG EXT THK.
- 6 INSULATION: MATERIAL: TEFLON (ASTM D3295)
COLOR: ORANGE
- 7 INSULATION: PVDF
COLOR: ORANGE

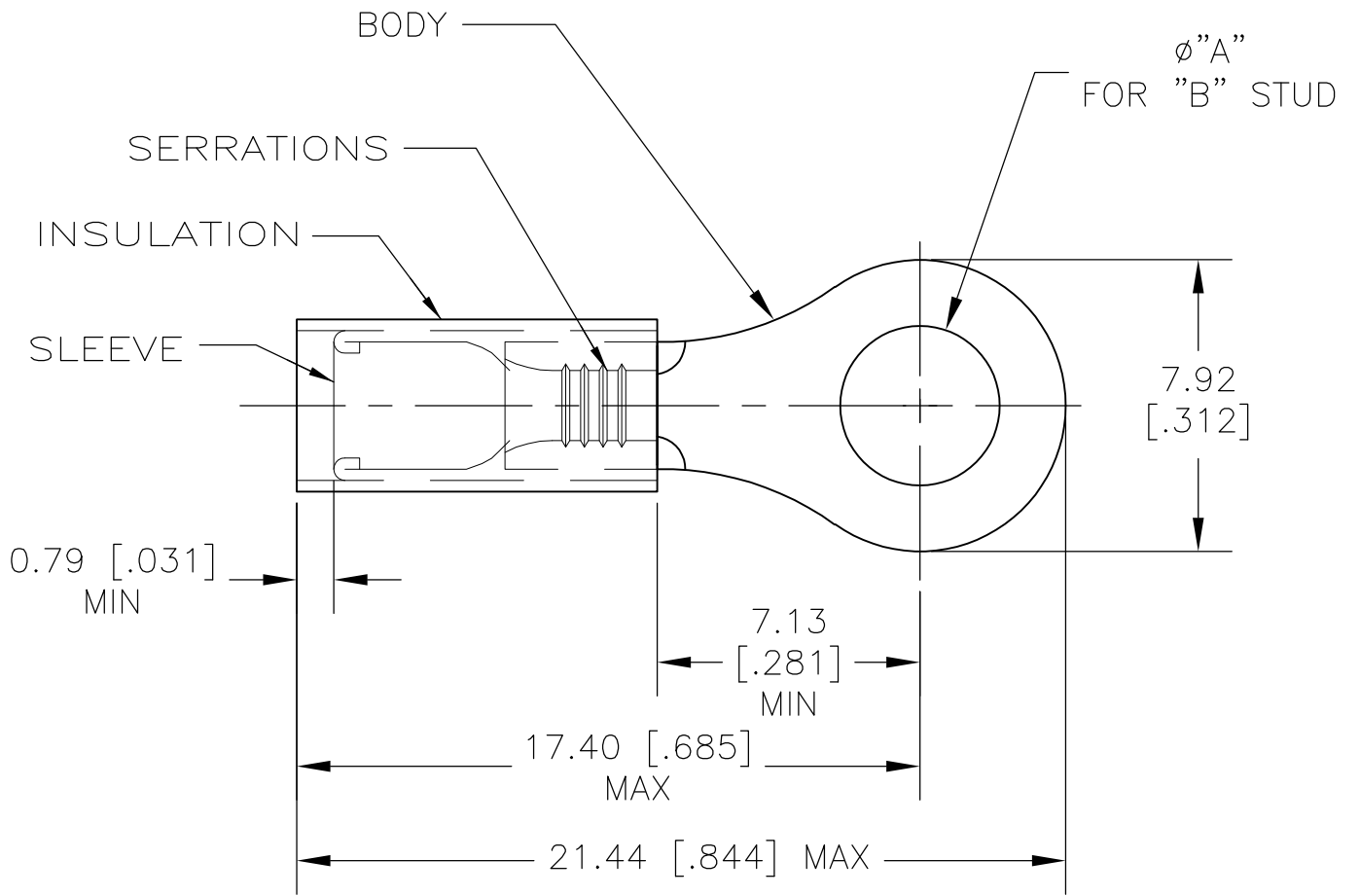

7	PRELIMINARY	#10	5.00±0.08 [.197±.003]	332454-2
7	PRELIMINARY	#8	4.34±0.08 [.171±.003]	332454-1
6		#10	5.00±0.08 [.197±.003]	1-332454-0
6		#8	4.34±0.08 [.171±.003]	332454
		"B"	"A"	PART NO.

AMP INCORPORATED CUSTOMER SERVICE SYSTEMS		MAX RECOMMENDED OPERATING TEMPERATURE: 260°C	THIS DRAWING IS A CONTROLLED DOCUMENT.		DWN JR RUTH 11JUL05	TE Connectivity NAME TERMINAL, PIDG , STRATO-THERM, RING TONGUE, WIRE SIZE: 18-16					
FOR ADDITIONAL PRODUCT INFORMATION OR COPIES OF DRAWINGS AND TECHNICAL DOCUMENTS	PRODUCT INFORMATION CENTER 1-800-522-6752	VOLTAGE RATING: 300V MAX	DIMENSIONS: INCHES	TOLERANCES UNLESS OTHERWISE SPECIFIED:	CHK T MICHELUTTI 11JUL05					APVD T MICHELUTTI 11JUL05	SIZE
FOR APPLICATION TOOLING INFORMATION	TOOLING ASSISTANCE CENTER 1-800-722-1111	CIRCULAR MIL AREA: 0.81-1.42mm² [1,600-2,800] STRANDED WIRE ONLY		0 PLC ± - 1 PLC ± - 2 PLC ± 0.20[.008] 3 PLC ± - 4 PLC ± - ANGLES ± -	PRODUCT SPEC	APPLICATION SPEC	WEIGHT	A3	00779	C-332454	
FOR ORDER ENTRY	1-800-526-5142		MATERIAL	FINISH	CUSTOMER DRAWING		SCALE	SHEET	REV		